

# Real Estate Sales Action Plan

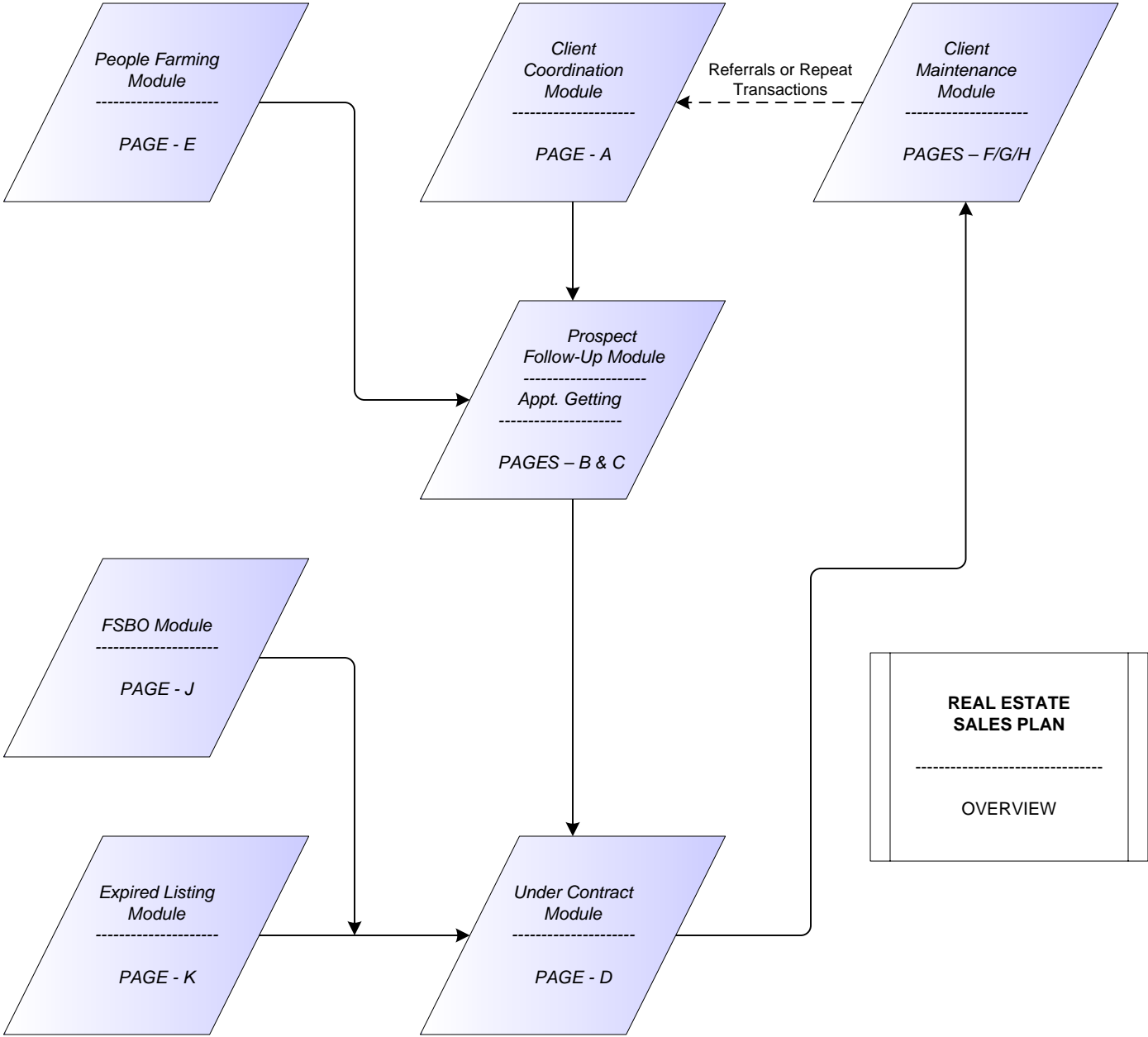

## LEGEND



# REAL ESTATE

## PAGE "A" - Client Coordinator / Open House / Referrals

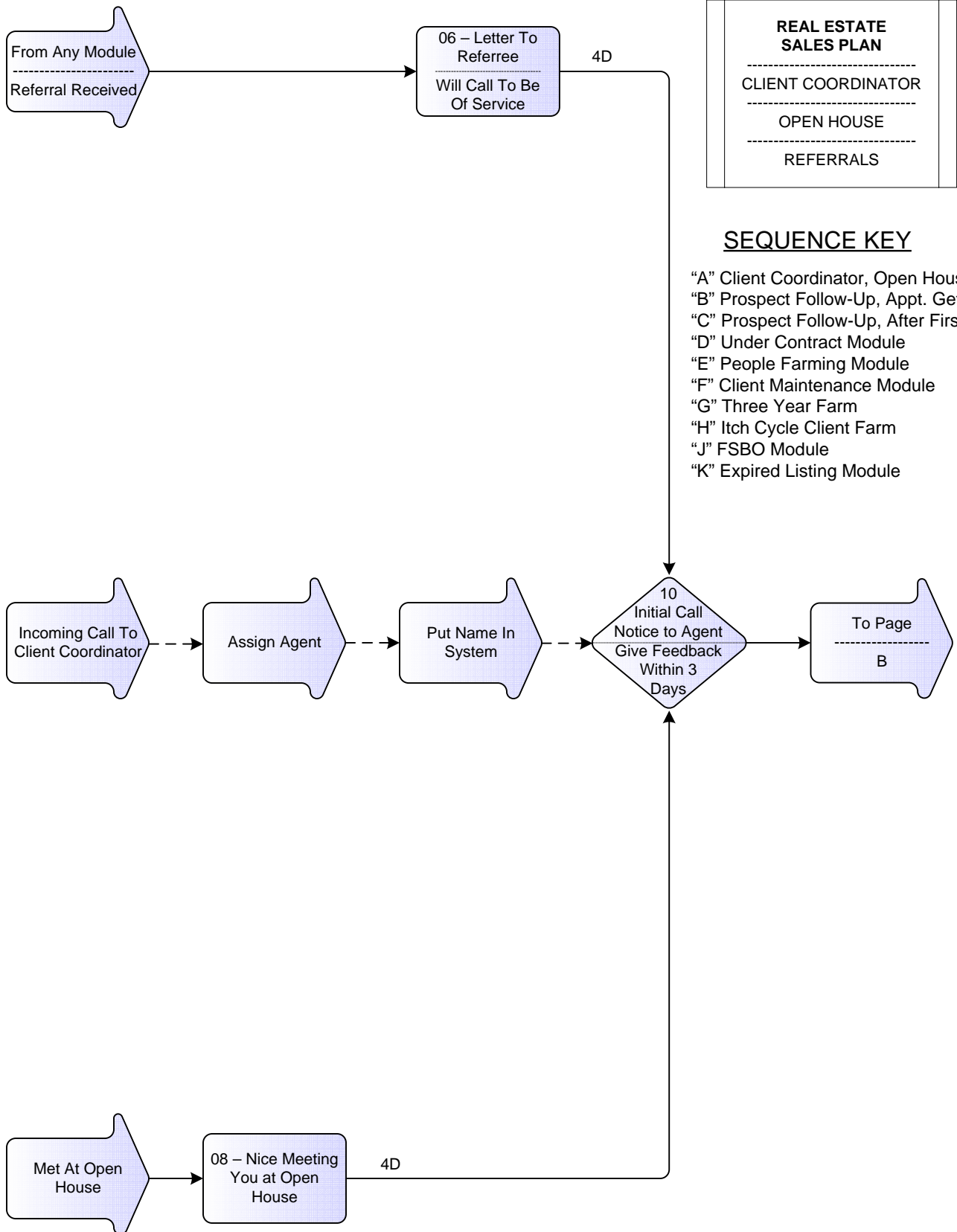

# REAL ESTATE SALES PLAN

## PAGE "B" - Prospect Follow Up & Appointment Getting

**REAL ESTATE  
SALES PLAN**

---

PROSPECT FOLLOW-UP  
APPOINTMENT GETTING

PAGE "B"

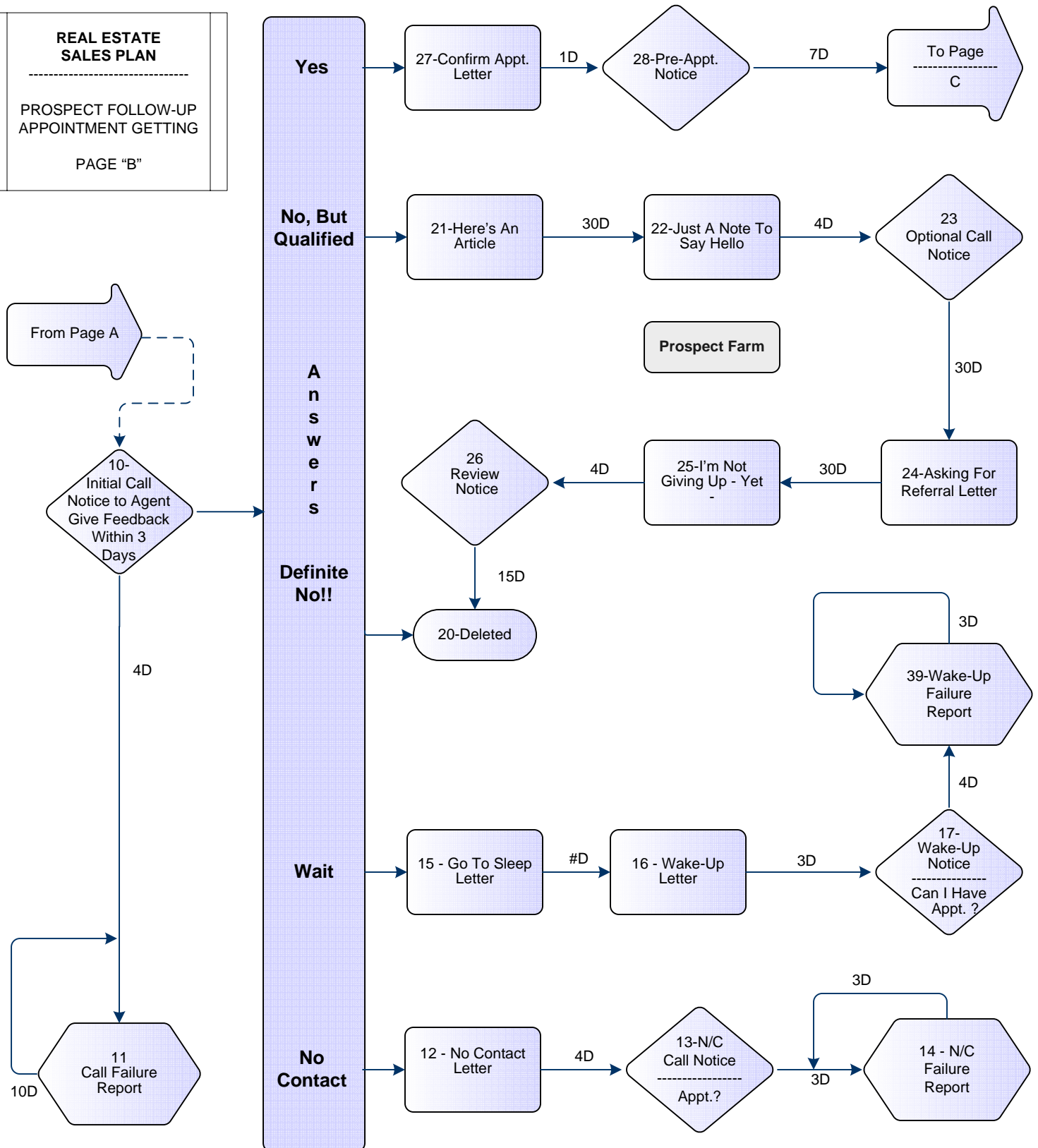

# REAL ESTATE

## PAGE "C" - Prospect Follow-Up / After First Appt.

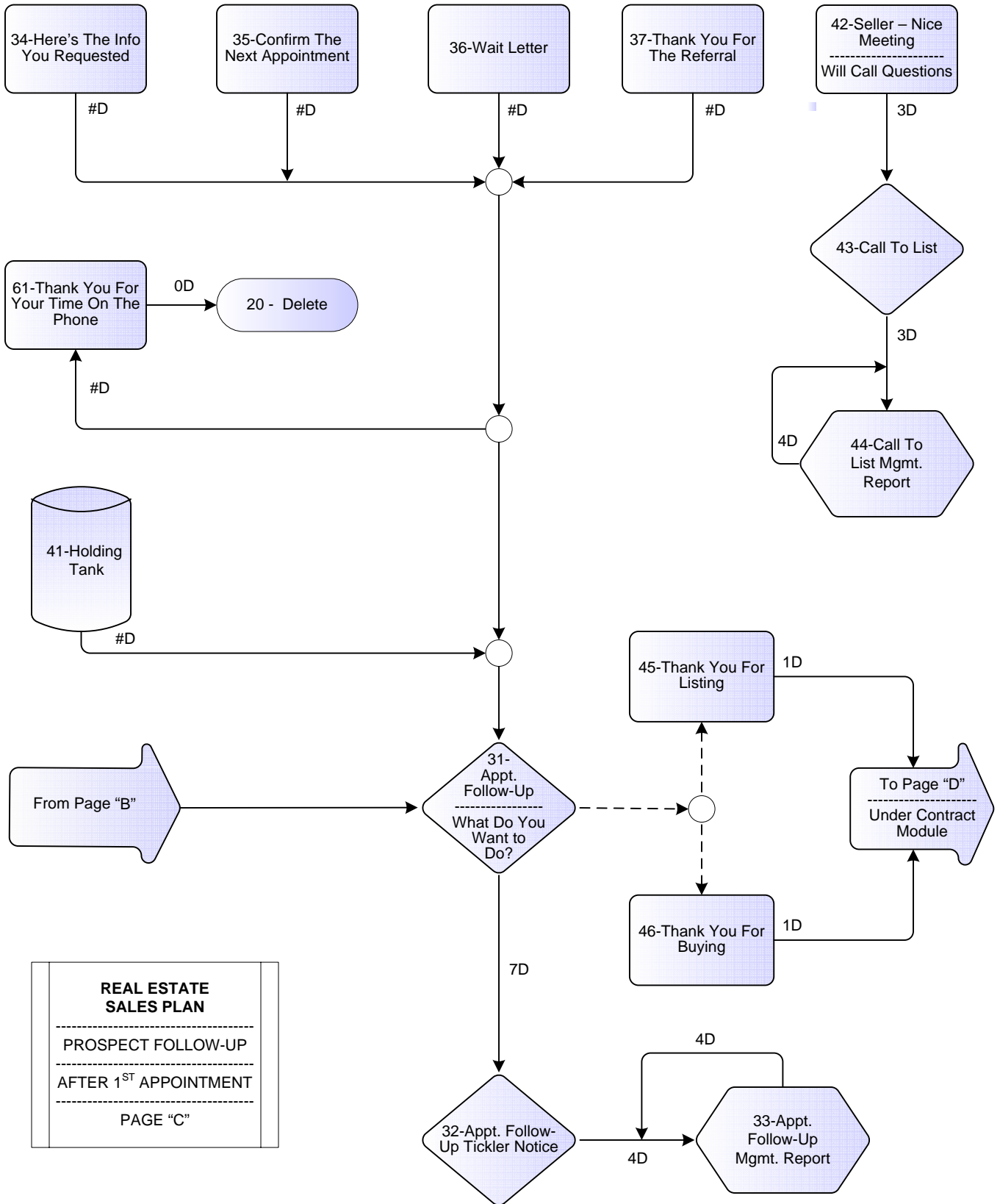

**REAL ESTATE  
SALES PLAN**  
 -----  
 PROSPECT FOLLOW-UP  
 -----  
 AFTER 1<sup>ST</sup> APPOINTMENT  
 -----  
 PAGE "C"

# REAL ESTATE

## PAGE "D" - Closing Actions

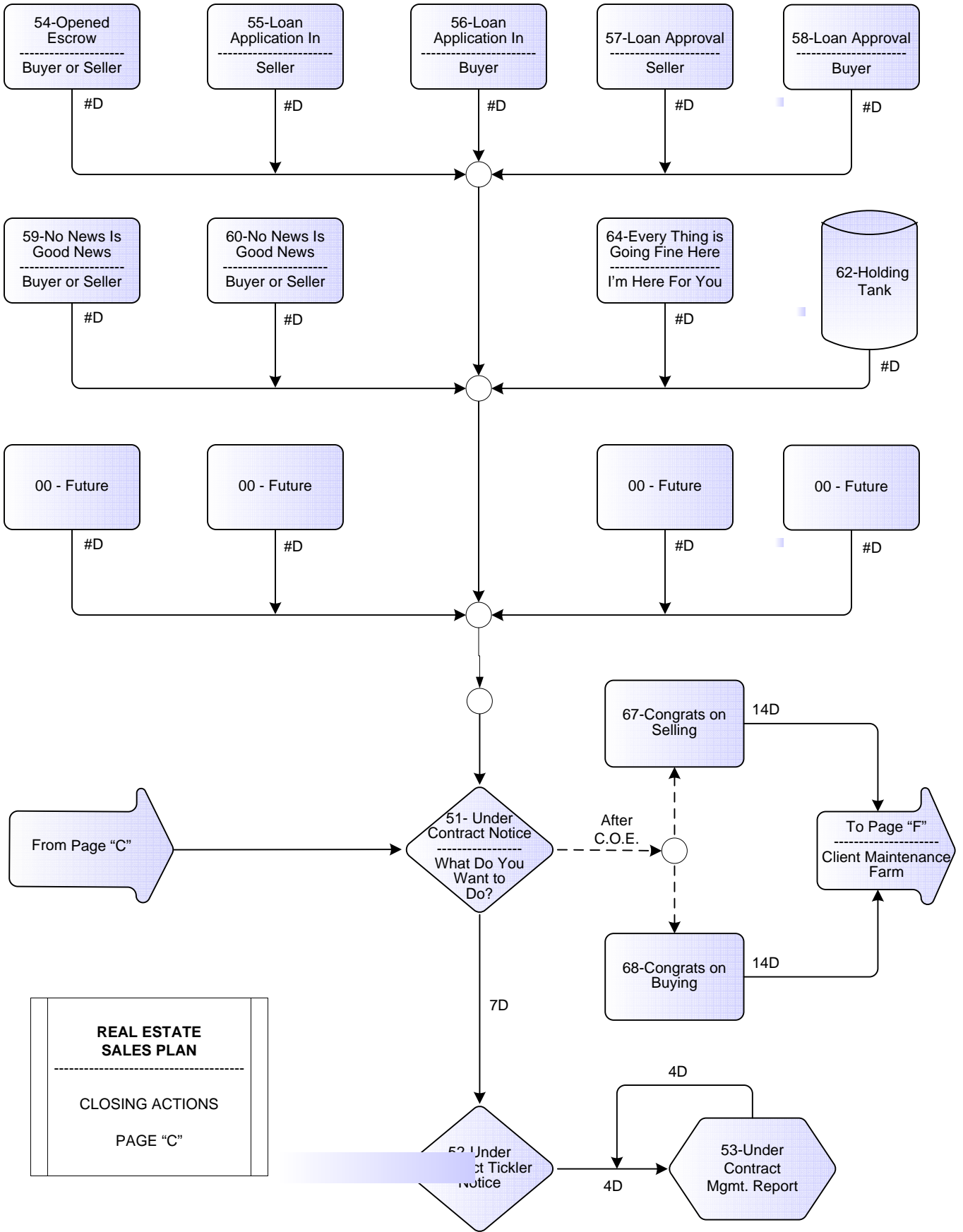

<b>REAL ESTATE SALES PLAN</b>
-----
CLOSING ACTIONS
PAGE "C"

# REAL ESTATE SALES PLAN "E" - PEOPLE FARM

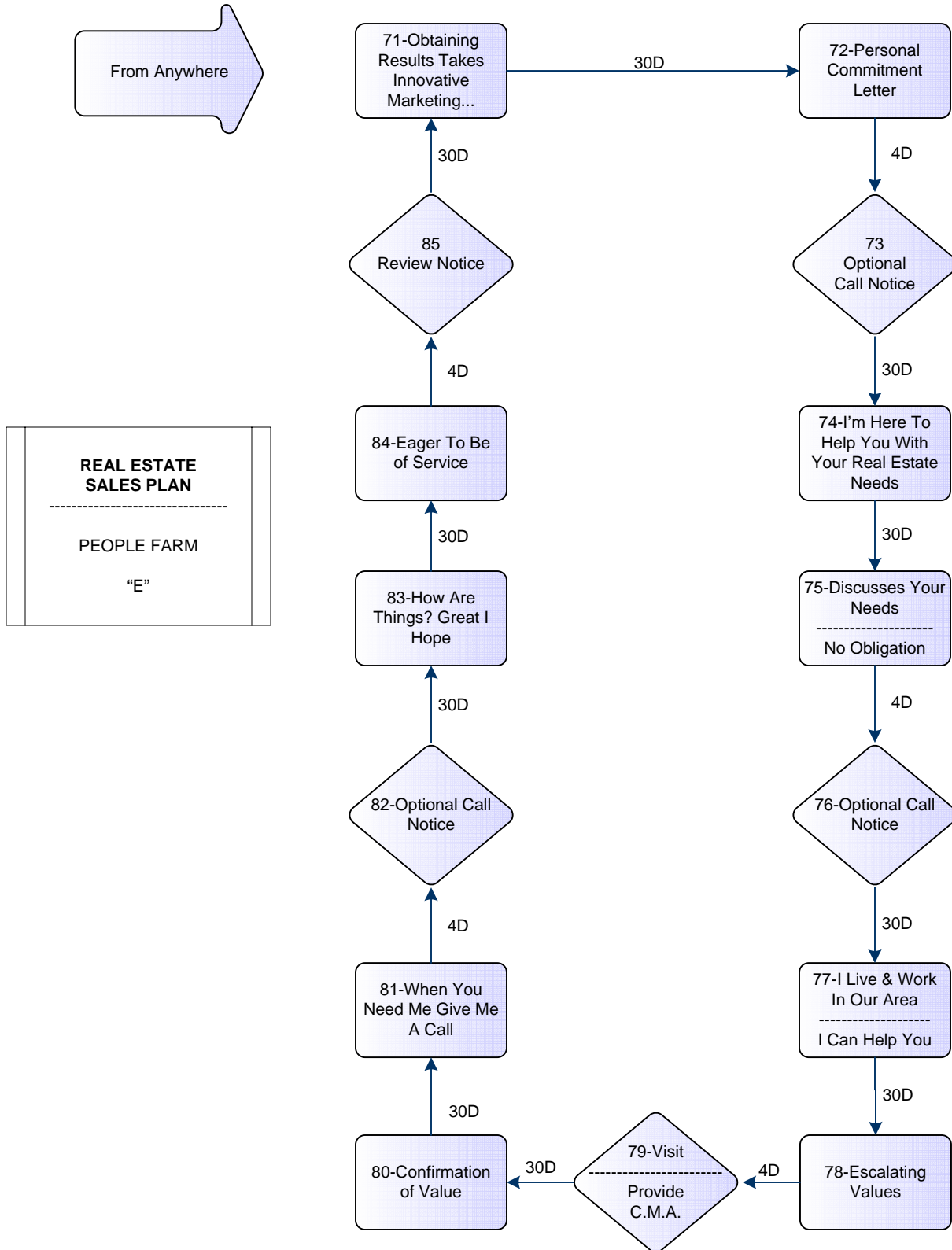

# REAL ESTATE SALES PLAN

## “F” - First Year / Client Maintenance Farm

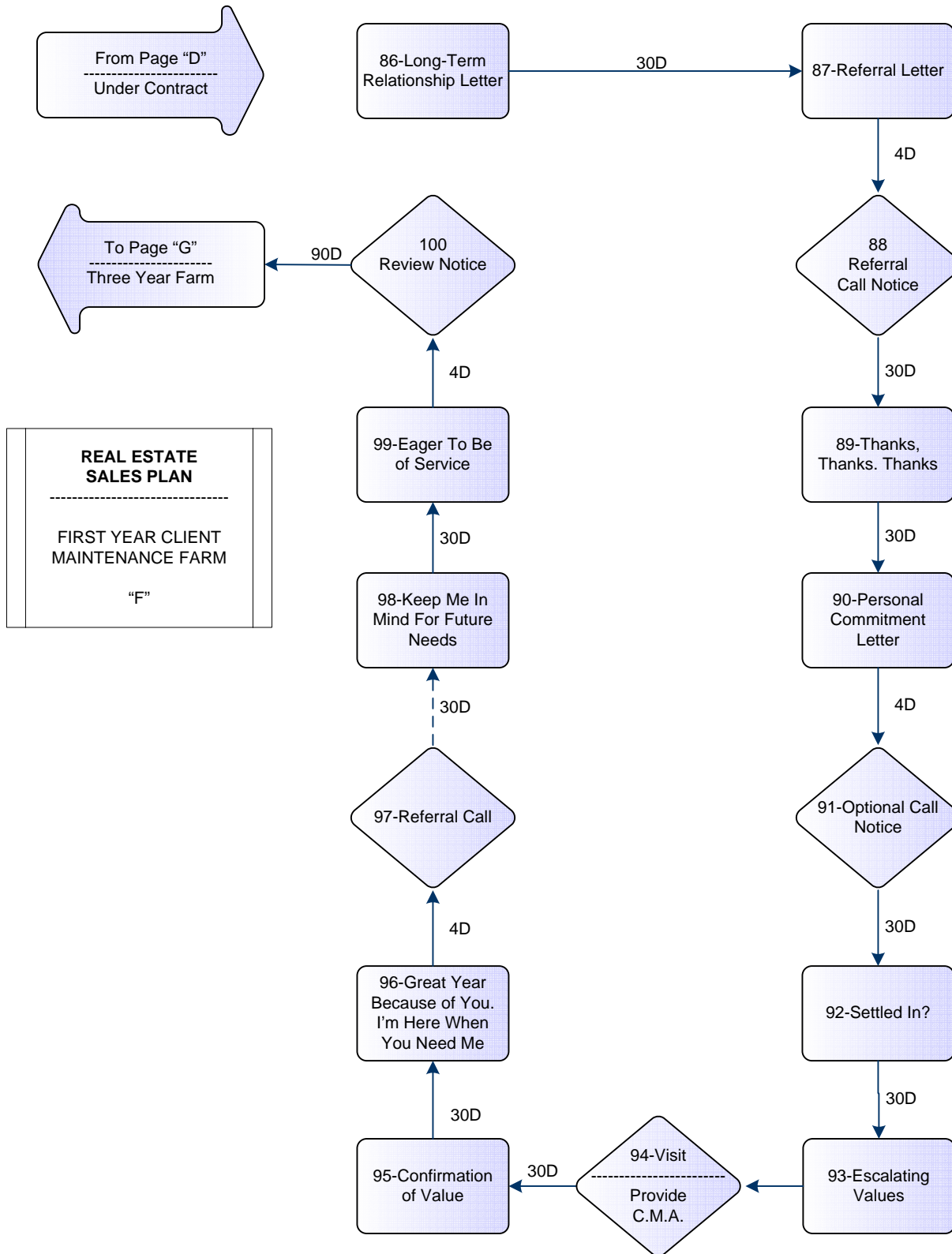

# REAL ESTATE SALES PLAN

## Page "G" - Three Year Farm

<b>REAL ESTATE SALES PLAN</b>
----- 3 YEAR FARM -----
2 <sup>ND</sup> THRU 4 <sup>TH</sup> YEAR OR 6 <sup>TH</sup> THRU 8 <sup>TH</sup> YEAR -----
PAGE "G"

From Page F  
1<sup>st</sup> Year  
----- OR -----  
Itch Cycle Farm

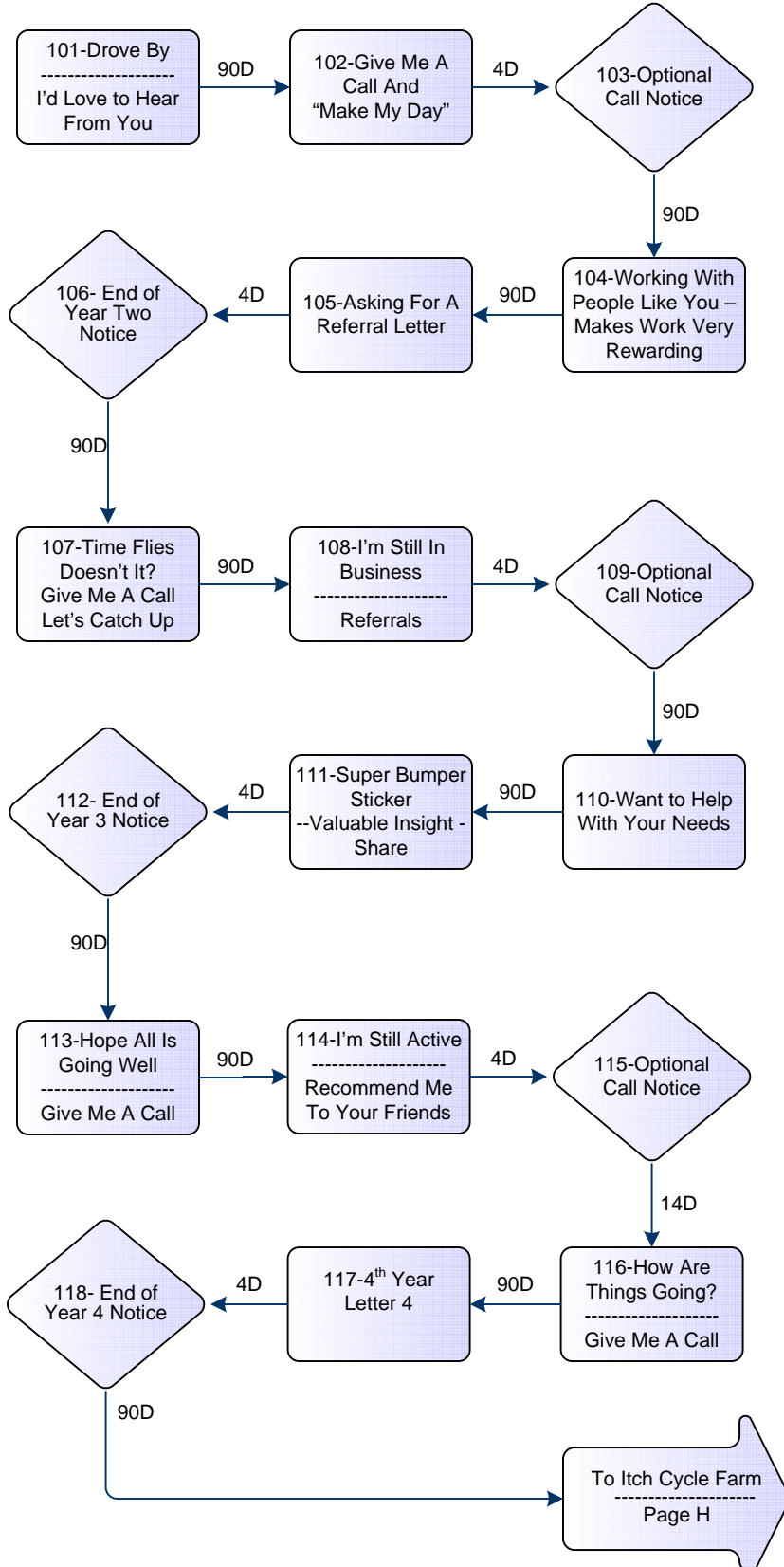

# REAL ESTATE SALES PLAN "H" - Itch Cycle Client Farm

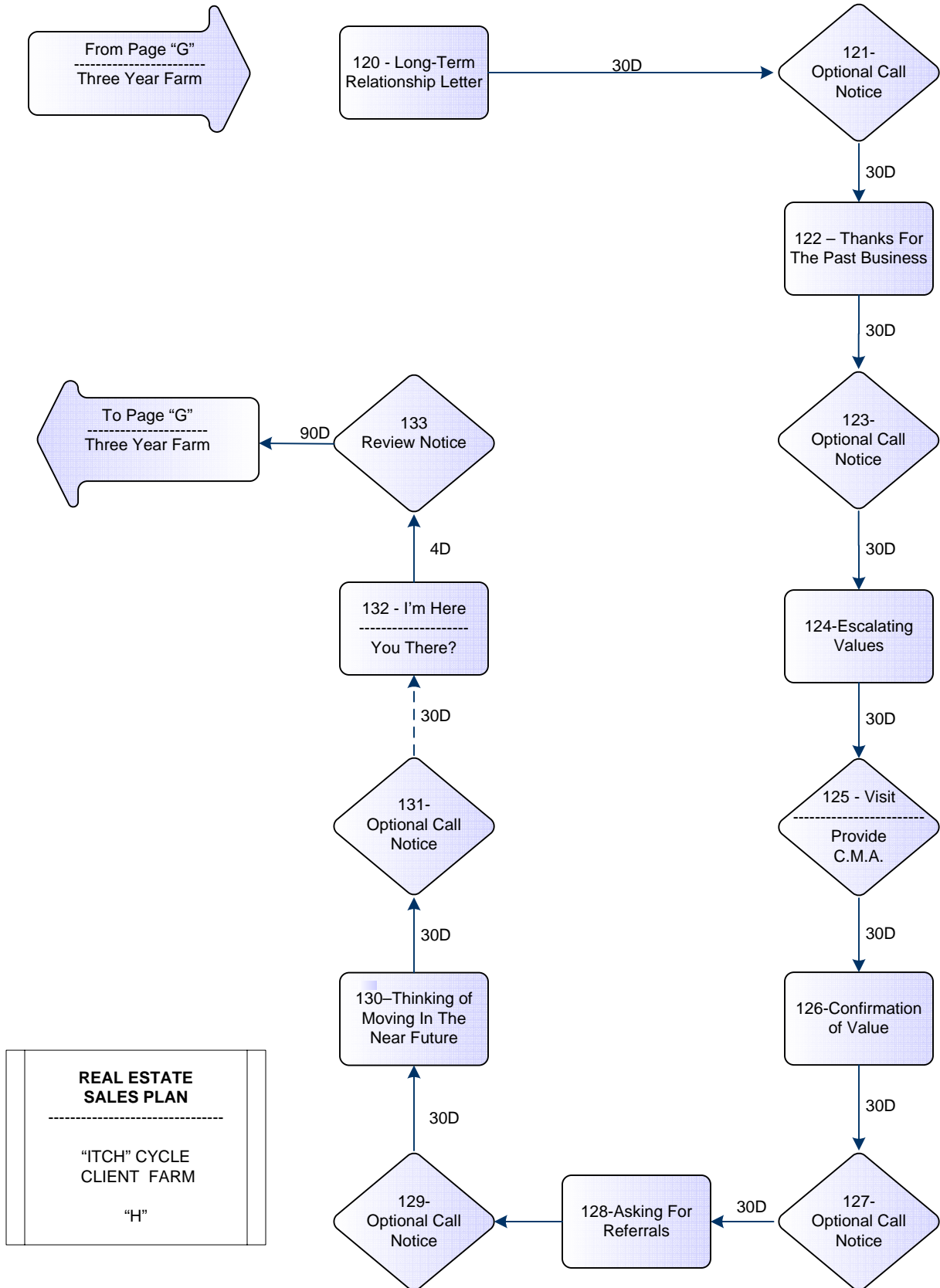

# REAL ESTATE SALES PLAN

## “J” - F.S.B.O. Module

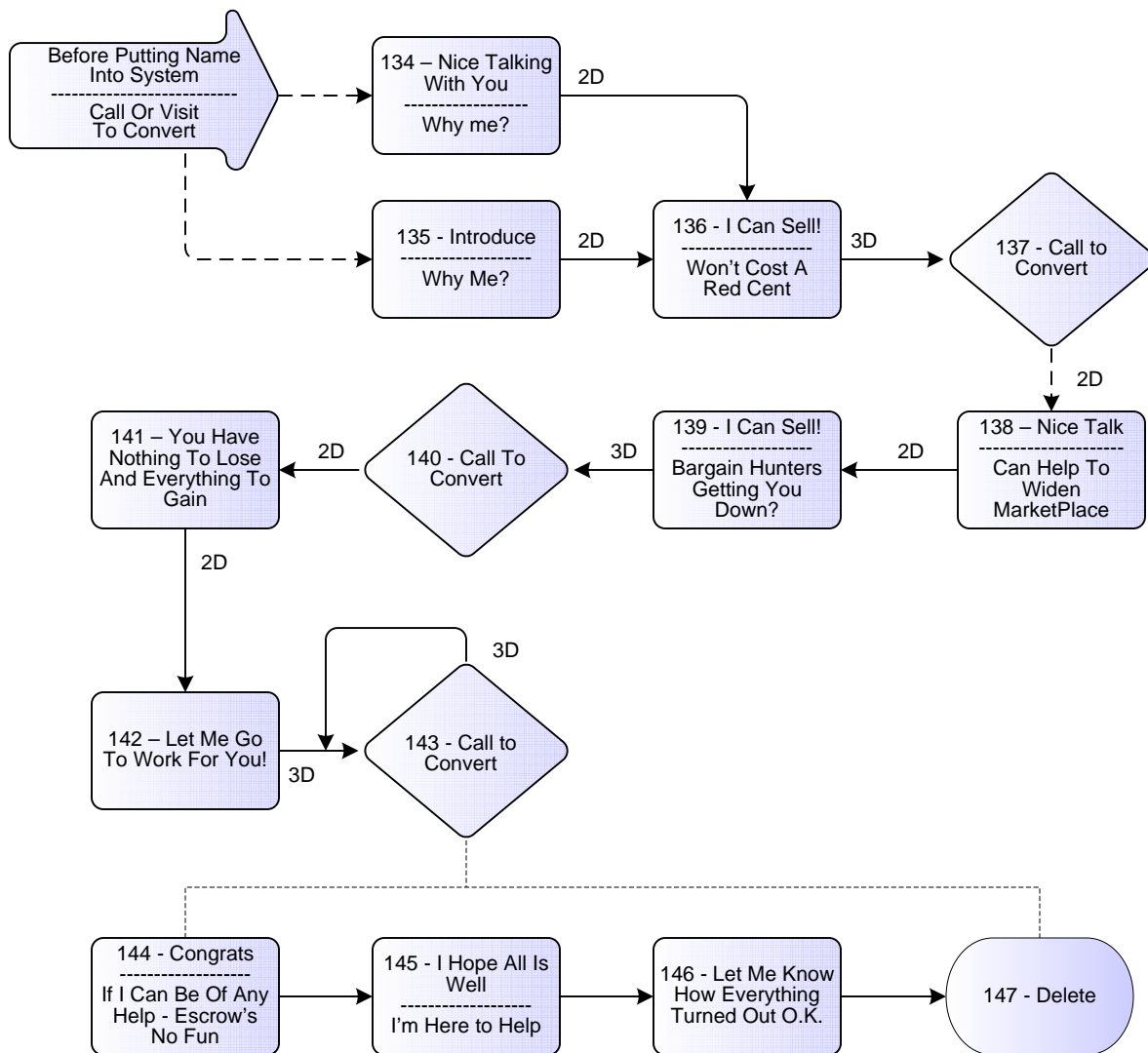
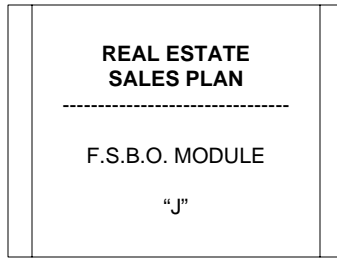

# REAL ESTATE SALES PLAN

## “K” - Expired Listings

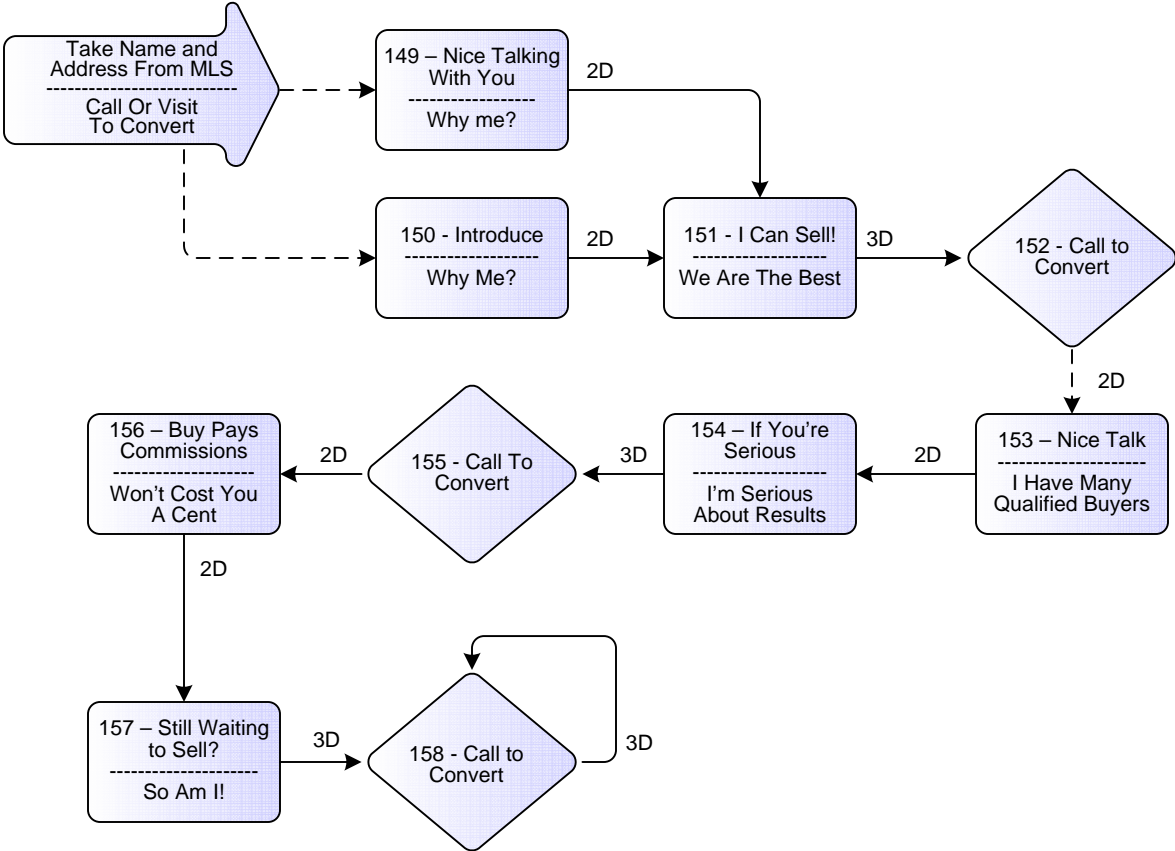

**REAL ESTATE SALES PLAN**

---

**EXPIRED LISTINGS**

“K”